



**MODERNIZATION OF RESEARCH AREA:
NATIONAL PROSPECTS
AND EUROPEAN PRACTICES**

Scientific monograph

Riga, Latvia
2022

UDK 001(08)
MO045

Title: Modernization of research area: national prospects and European practices

Subtitle: Scientific monograph

**Scientific editor and
project director:**

Anita Jankovska

Authors: Nataliia Pinchuk, Oleksandr Terletsnyi, Yuliia Aleskerova, Lidia Fedoryshyna, Liudmyla Boltovska, Kateryna Burko, Sergii Ivanov, Natalya Osadchaya, Hanna Razumova, Olesia Lemishovska, Dmytro Sopov, Tetiana Karpenko, Andrii Sryberko, Serhiy Burlaka, Tetiana Yemchik, Serhiy Burlaka, Natalia Telekalo, Julia Poberezhets, Mykhailo Zamrii, Olena Solona, Ihor Kupchuk, Ihor Tverdokhlib, Yurii Polievoda, Vitalii Yaropud, Inna Honcharuk, Pavlo Leontiev, Inna Torianyuk, Svitlana Kalinichenko, Oksana Starishko, Olha Voronkova, Olha Voronkova, Yuliia Voronkova, Taisiya Shevchenko, Svitlana Koshova, Artem Androsenko, Ljudmila Dovbnia, Petro Dovbnia, Kateryna Kovalova, Tetiana Ponomarenko, Tetiana Shynkar, Svitlana Kaleniuk, Iryna Loshchenova, Marta Karp, Lyudmila Maystrenko, Anzhelika Solodka, Tatiiana Moroz, Oksana Sinenko

Publisher: Publishing House "Baltija Publishing", Riga, Latvia

Available from: <http://www.baltijapublishing.lv/omp/index.php/bp/catalog/book/234>

Year of issue: 2022

All rights reserved. No part of this book may be reprinted or reproduced or utilized in any form or by any electronic, mechanical, or other means, now known or hereafter invented, including photocopying and recording, or in any information storage or retrieval system, without permission in writing from the publisher and author.

Modernization of research area: national prospects and European practices: Scientific monograph. Riga, Latvia: Baltija Publishing, 2022. 712 p.

ISBN: 978-9934-26-221-0

DOI: <https://doi.org/10.30525/978-9934-26-221-0>

The scientific monograph presents the theoretical and practical aspects of the modernization of research area: national prospects and European practices. General questions of economics and enterprise management, technical sciences, technology of food and light industry, physical and mathematical sciences, geographical sciences, medical sciences, legal sciences, national security issues, pedagogical and philological sciences, and so on are considered. The publication is intended for scientists, educators, graduate and undergraduate students, as well as a general audience.

© Izdevniecība "Baltija Publishing", 2022
© Authors of the articles, 2022

Table of Contents

CHAPTER «PHYSICAL AND MATHEMATICAL SCIENCES»

Nataliia Pinchuk, Oleksandr Terletskyi

NANOSTRUCTURED COATINGS ZRN, OBTAINED
BY VACUUM-ARC DEPOSITION METHOD. 1

CHAPTER «ECONOMIC SCIENCES»

Yuliia Aleskerova, Lidiia Fedoryshyna

HEALTH INSURANCE, PROSPECTS OF DEVELOPMENT IN UKRAINE. 19

Liudmyla Boltovska

CURRENT TRENDS IN THE DEVELOPMENT
OF THE MEAT PRODUCT SUBCOMPLEX OF UKRAINE
IN THE CONTEXT OF EUROPEAN INTEGRATION. 52

Kateryna Burko

METHODS OF TRAINING OF ACCOUNTING SPECIALISTS
IN THE CONDITIONS OF DISTANCE EDUCATION. 87

Sergii Ivanov, Natalya Osadchaya, Hanna Razumova

STRATEGIC DIRECTIONS
OF UKRAINE'S EXPORT STRATEGY FORMATION. 108

Olesia Lemishovska

CAPITAL IN ACCOUNTING WORKS OF SCIENTISTS
OF GALICIA IN THE SECOND HALF OF THE XIX –
MIDDLE OF THE XX CENTURY: RETROSPECTIVE ANALYSIS
AND EVALUATION FROM THE POSITION OF MODERN LANDMARKS. 139

CHAPTER «GEOGRAPHICAL SCIENCES»

Dmytro Sopov, Tetiana Karpenko

GEOSPATIAL FEATURES OF LAND USE AND NATURAL PREREQUISITES
FOR LAND DEVELOPMENT IN LUHANSK REGION (UKRAINE). 161

Andrii Sryberko

CALCULATION OF THE VERTICAL DISTRIBUTION
OF THE SPEED OF SOUND IN THE BLACK SEA BASED
ON SATELLITE DATA IN THE PERIOD SPRING – AUTUMN 2021. 184

CHAPTER «AGRICULTURAL SCIENCES»

Serhiy Burlaka, Tetiana Yemchik

IMPROVING THE EFFICIENCY OF THE USE OF BIODIESEL
FUEL MIXTURES IN THE SYSTEMS OF AUTONOMOUS ENERGY
SUPPLY OF AGRICULTURAL ENTERPRISES 205

Serhiy Burlaka, Natalia Telekalo

MODERNIZATION OF THE POWER SUPPLY SYSTEM
OF A DIESEL POWER PLANT 238

Julia Poberezhets, Mykhailo Zamrii

EFFICIENCY OF USING A PROBIOTIC FEED ADDITIVE
IN FEEDING KURCHAT BROILERS 270

Olena Solona, Ihor Kupchuk

DEVELOPMENT OF A FUNCTIONAL MODEL OF A VIBRATING MILL
WITH ADAPTIVE CONTROL SYSTEM OF MODE PARAMETERS 302

Ihor Tverdokhlib, Yurii Polievoda

THE INFLUENCE OF PARAMETERS OF RUNNING SYSTEMS
AND THEIR SUSPENSION ON THE SAFETY OF OPERATORS
OF MOBILE MACHINES AND ENERGY EQUIPMENT 329

Vitalii Yaropud, Inna Honcharuk

DEVELOPMENT AND JUSTIFICATION OF CONSTRUCTIVE-REGIME
PARAMETERS OF THE AUTOMATED SYSTEM OF MICROCLIMATE
PROVISION IN APC PREMISES 360

CHAPTER «MEDICAL SCIENCES»

Pavlo Leontiev, Inna Torianyk, Svitlana Kalinichenko

PARAMETERS OF BLOOD AND ERYTHROCYTES AS MARKERS
OF AGE OF OCCURRENCE OF HEMATOMAS IN LIVING PERSONS 390

Oksana Starishko, Olha Voronkova

LACTOBACYLLI IN THE MICROBIOTA OF THE REPRODUCTIVE
TRACT OF WOMEN WHO SMOKE AND DO NOT SMOKE 409

CHAPTER «PHYSICAL EDUCATION AND SPORT»

Olha Voronkova, Yuliia Voronkova

CHONDROMALATION: DIAGNOSIS, TREATMENT, REHABILITATION . . . 433

**DEVELOPMENT OF A FUNCTIONAL MODEL
OF A VIBRATING MILL WITH ADAPTIVE CONTROL SYSTEM
OF MODE PARAMETERS**

Olena Solona¹
Ihor Kupchuk²

DOI: <https://doi.org/10.30525/978-9934-26-221-0-12>

Abstract. The research was supported and funded by the Ministry of Education and Science of Ukraine under grant No. 0121U108589 «Development of a complex of energy-efficient and resource-saving equipment and promising technologies for feeding farm animals of the AIC of Ukraine». The introduction of energy-efficient machines and technologies in the system of feed preparation and animal feeding is an important prerequisite for the development of agriculture. One of the advanced types of grinding technology are vibrating mills, which provide high specific productivity at relatively low energy consumption, adjustable tone of grinding products.

Vibration impact on the product significantly increases the shock-absorbing effect with the possibility of wide and separate variation of shock and abrasion factors. Significant speed of mechanical and heat and mass transfer processes, a high degree of homogeneity of the product, the ability to effectively implement fine grinding and dispersion of the product at relatively low energy consumption lead to the widespread use of vibratory grinding.

The constructive scheme of the mill is developed, in which the flat vertical vibrating field provides lifting of a part of loading and by means of the transport-reloading device carries out its continuously regulated movement from one grinding chamber to another, thereby circulating-spatial movement of the environment in which grinding shock interaction of grinding bodies and material that is crushed.

One of the most important rules for the construction of vibrating mills is the need to maximize the degree of their automation in order to increase

¹ Candidate of Technical Sciences, Associate Professor,
Vinnitsa National Agrarian University, Ukraine

² Candidate of Technical Sciences, Associate Professor,
Vinnitsa National Agrarian University, Ukraine

productivity, improve the quality of grinding and reduce the cost of the technological process.

A constructive model of a controlled vibration mill with spatial-circulating motion was also developed, which constantly changes to the resonant mode of operation at the set technologically optimal parameters (productivity) and minimum energy consumption for vibration when changing the mass of the working body in the process of separation and unloading of crushed material from the grinding chamber.

The aim of the study is to establish the dependence of the parameters of the crushed mass along the grinding chambers and in places of overload on the parameters of vibration of the vibration mill of continuous motion.

Development of a structural model of adaptive vibration mill with spatial-circulating loading movement which when changing the mass of the working body in the process of separation and unloading of crushed material from the grinding chamber could constantly adapt to resonant mode at given technologically optimal parameters (productivity) and minimum energy consumption

Research methods. Theoretical and experimental research methods were used in the work. Experiment planning and regression analysis methods were used in conducting experiments and processing experimental data. Verification of the adequacy of the obtained dependences with experimental data was carried out by methods of mathematical statistics.

Scientific novelty: the theory and practice of vibration mechanics were further developed, in particular, the conditions of vertical lifting of the loading part in vibrating mills with a U-shaped chamber were determined and the influence of the main factors on the lifting height was studied; for the first time the scheme of the vibrating mill with spatial-circulating loading movement is developed, in which the effect of lifting of loading is used and by means of the transport-technological device reloading in the interconnected chambers is carried out.

Practical significance. The conditions and parameters of the vibration field that regulate the intensity and duration of grinding are determined. The dependence of the productivity Q of a vibrating mill on the velocity of transporting the loaded mass along the grinding chamber has been established. The structure and two-circuit principle of control of work of adaptive vibration mill with spatial-circulating movement of loading are offered.

1. Introduction

Domestic and foreign practice has accumulated extensive experience in the production and use of complete, balanced feed mixtures. These compound feeds contain components of plant, animal and biological origin, biologically active substances, drugs, flavoring additives – everything that contributes to the growth and preservation of animal health [21; 22].

Experience indicates that it is necessary to introduce high-tech machines for the production of animal feed [26]. It is more profitable to produce them in the conditions of small feed mills or directly in the conditions of fattening complexes, where the specifics of local raw materials are taken into account and there are no significant costs for transporting finished products. In the conditions of Ukraine, where there is a whole network of inter-district feed mills, this experience, combined with domestic achievements, must be effectively introduced into production without significant additional costs. At creation of vibrating mills of continuous action with spatial circulating movement of loading (grinding bodies and the crushed material) two main problems are solved: maintenance of circulating movement of loading; separation and unloading of crushed material from the grinding chamber. The implementation of a continuous technological process makes it possible to realize the dynamism and direction of product processing, to ensure synchronicity and proportionality between the main and auxiliary operations, thus determining the highest technical and economic parameters of technological equipment.

Given the fact of particularly high specific energy of vibration mills and constant changes in the load mass of the working body (grinding chamber) as a result of circulating loading movement is constantly separating and unloading crushed material from the grinding chamber there is a constant change in natural resonant frequency vibration mill. As a result, the constant resonant modes of operation of vibrating machines of this class are not provided, which in turn does not provide the minimum energy consumption for the vibrating drive and reduces the technical and economic parameters of this technological equipment.

Considering the widespread use of vibration mills in the technology of compound feed and premix preparation and taking into account their high energy stress (energy spent on the destruction of one gram-molecule of a crystalline compound), it is advisable to constantly adapt the frequency of

the driving force to the frequency of natural oscillations. resonant mode of operation of this electromechanical system.

2. Theoretical prerequisites for the development of vibration mills

One of the main parameters of the vibrating mill is the energy consumed by the technological load. The energy supplied to the vibrating exciter of the mill is spent on overcoming the friction losses in the bearing units of the drive. hysteresis losses in the elastic bonds of vibration mill, as well as to maintain the oscillating motion of the technological load [1].

The energy supplied to the technological loading is spent on the inelastic deformation of the grinding bodies and the crushed material when they collide, overcoming the resistance forces of the loading movement and the formation of a new surface of the crushed material. In part, this energy is converted into heat, which is then dissipated by convection and radiation [6; 10].

The energy consumed in the technological loading of the mill is 80-90% of the total energy supplied from the outside and is therefore decisive in choosing the engine power of the vibrating mill.

The amount of energy supplied from the outside is proportional to the kinetic energy of the grinding chamber with loading [2; 3], ie:

$$E = m_3 A^2 \omega^2, \quad (1)$$

E – supplied energy; m_3 – mass of technological loading; A – amplitude of oscillations of the grinding chamber; ω – the frequency of oscillations.

With the increase in the amount of energy consumed, the work of grinding increases [1]. However, the implementation of high technological parameters of grinding is not always possible due to the limited dynamic strength of the elements of the vibrating mill. Therefore, when creating vibrating mills with large grinding chambers, it is recommended to accept modes with acceleration levels less than 15. Based on experimental studies [4; 6] we will consider acceptable for the rational technological process of the amplitude of oscillations $A = 0.5-4.2$ mm at oscillation frequencies of the grinding chamber $\omega = 60-120$ rad / sec.

Assuming the proportionality of the forces of inelastic resistance to the first degree of the velocity of movement of the grinding chamber, the amount of power consumed by the load is defined as [14]:

$$N_3 = \alpha A^2 \omega^2, \quad (2)$$

a – the coefficient of proportionality:

$$\alpha = \left(\frac{a}{A} \right) m_3 \omega. \quad (3)$$

The value of the coefficient $\frac{a}{A}$ characterizing the inelastic supports of the technological load is determined by experimental studies. In Figure 1 are presents the value for the technological load, consisting of steel balls and crushed material, and the ratio of their volumes.

Knowing the dependences of α , N_3 and the amplitude of oscillations, it is convenient to determine the power consumed during the technological process, according to the nomogram (Figure 2). Usually the value of the mass of the technological load is known. According to the technological amplitude and frequency of oscillations in the first quadrant, the values of kinematic energy and levels of accelerations are determined.

According to the selected mass of technological loading and the frequency of oscillations at a given ratio of volumes between the material to be crushed and the grinding bodies, the values of inelastic resistances of technological loading are determined in the third quadrant. The intersection of two perpendiculars, which characterize the found values of the square of the velocity of the grinding chamber and the coefficient of inelastic resistance of the technological load give us the value of the required power spent on grinding the processed product.

Next, for the adopted design scheme and on the basis of data, you need to calculate the vibrators, as well as check to ensure their synchrony with the required phasing of the rotation. If necessary, make a constructive improvement of grinding chambers in order to establish the necessary and sufficient conditions for the stability of synchronous rotation of vibrators.

3. The results of experimental studies of the parameters of the vibrating mill

3.1 Materials and methods

The experiments were performed on a vibrating mill MVE-5 in the version with a vertical chute. To do this, the reloading chute 6 was removed (Figure 3 and Figure 4), the end of the left grinding chamber was closed with a lid, and

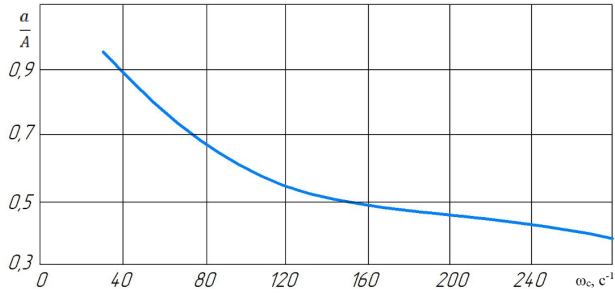

Figure 1. Dependence of the coefficient $\frac{a}{A}$ on the frequency of oscillations

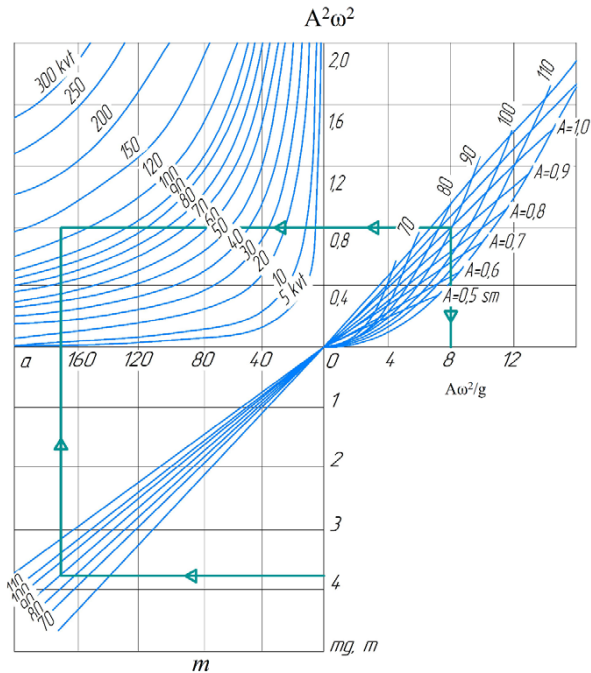

Figure 2. Nomogram for determining the power consumed for grinding

Source: [2; 4]

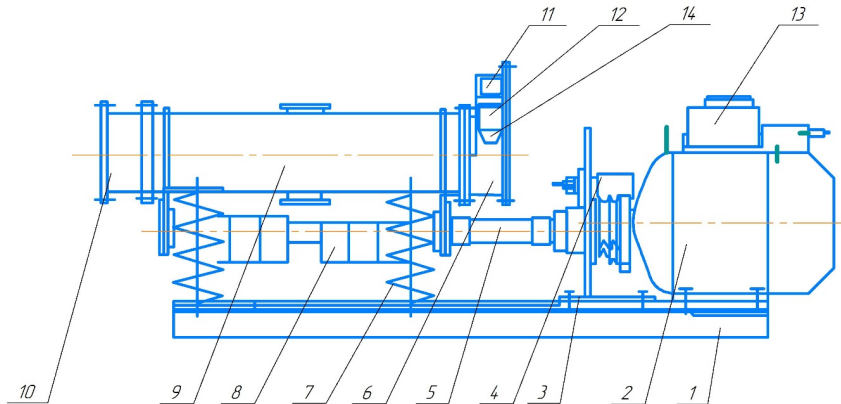

Figure 3. Constructive scheme of the experimental vibrating mill of continuous action MVE-5: 1 – frame; 2 – electric motor; 3 – V-belt transmission; 4 – riser; 5 – elastic cardan shaft; 6 – reloading chute; 7 – elastic supports; 8 – vibrating exciter; 9 – grinding chambers; 10 – transitional gutter; 11 – loading branch pipe; 12 – unloading tray; 13, 14 – control panels

a vertical chute was installed at the end of the right grinding chamber. It is made folded with a hinged connection between the elements of the gutter, connected by an elastic sleeve. The upper part of the gutter with an elastic element was attached to the arch fixed on the table. A mill was installed on the same table.

This arrangement of the mill with the gutter allowed to minimize its impact on the oscillations of the grinding chamber. When lifting the load on the gutter, in the grinding chamber, from which the load came into the chute, all the time received a load on the transition chute 10 from another grinding chamber. Thus, in the grinding chamber on which the gutter was installed, the loading level remained stable, which provided sufficient accuracy of the experiment. Changing the velocity of the vibrator was carried out using a V-belt transmission that connects the motors to the drive station of the vibrator.

Measurement of the lifting height of the load was carried out when the drive motor was stopped after reaching its maximum height. To determine the errors of the experiments, a series of seven measurements of the value of h_i , for all materials and the average values of the amplitude $A = 2$ mm angular frequency.

Due to the fact that the vertical chute, due to its transformation, is a loading chute loading from one grinding chamber to another, the lifting height of the load in it should directly affect the velocity of transporting the load along the grinding chambers. Consequently, the study of the influence of changes in the parameters of the oscillations of the grinding chamber on the height of the load rise on the vertical chute are decisive.

The experiments were performed on a vibrating mill MVE-5 (Figure 3 and Figure 4). Changing the oscillation parameters of the grinding chamber was carried out as in the case of the mill with a vertical chute.

The velocity of transporting the download was determined as follows.

Grinding chambers, as well as reloading and transitional chutes were filled with the investigated material by 76% of their total volume, based on the fact that

when redistributing the load in the grinding chambers during the operation of the mill in each of them formed normally rotating loading flows rise on a vertical gutter at the minimum parameters of fluctuations of the grinding chamber. The velocity of transporting the load was determined:

$$V_{TR} = V_{TR} = \frac{Q_{CP}}{S},$$

where Q_{CP} is the average productivity of the vibrating mill,

kg/s, S – cross-sectional area of the load in the grinding chamber, m^2 ; ρ – loading density, kg/m^3 .

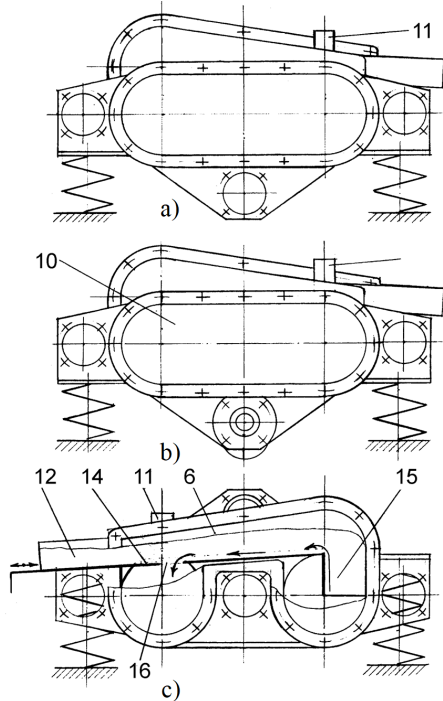

**Figure 4. Scheme of regulation of supply of loading of a mill of MVE-5:
14 – sunroof; 15 – vertical gate;
16 – reloading window**

3.2 Regression analysis of research results

For the response function h (height of the rise of the medium), the regression equation according to the conducted multivariate experiment for the coded values has the form:

$$h = 340,06 + 8,93x_1 + 6,77x_2 - 42,5x_3 - 33,1x_1x_2 - 15,6x_1x_3 - 15,3x_2x_3 - 53,5x_1^2 - 15,4x_2^2 + 5,06x_3^2 \quad (4)$$

Wherein $S_{aiom}^2 = 55,2$; $S_{ao}^2 = 159$; $F = 2,878 < [F] = 2,881$, therefore, the regression model (4) is adequate. Correlation coefficient $R^2 = 0,9906$.

All coefficients of the regression equation (4) turned out to be significant.

For real values of the factors, the regression equation for the response function h has the form:

$$h = -50617,3 + 199,5\omega + 185,6A + 4,25\rho - 0,935\omega A - 2,13 \cdot 10^{-4} \omega \rho - 0,0208A\rho - 0,0151\omega^2 - 43,6A^2 + 3,32 \cdot 10^{-6} \rho^2 \quad (5)$$

For the transport velocity response function V_{TP1} when the vibration exciter is placed in the center of the oscillating masses (the central location of the vibration exciter), the regression equation according to the conducted multifactorial experiment for the coded values has the form:

$$V_{TP1} = 8,57 + 2,81x_1 + 1,22x_2 + 0,646x_3 + 0,558x_1x_2 + 0,03x_1x_3 + 0,128x_2x_3 - 1,22x_1^2 - 1,1x_2^2 - 0,151x_3^2 \quad (6)$$

discarding minor effects of interactions, the regression equation (6) in coded values is as follows:

$$V_{TP1} = 8,57 + 2,81x_1 + 1,22x_2 + 0,646x_3 + 0,558x_1x_2 - 1,22x_1^2 - 1,1x_2^2 - 0,151x_3^2 \quad (7)$$

Wherein $S_{aiom}^2 = 0,049$; $S_{ao}^2 = 0,114$; $F = 2,306 < [F] = 2,770$, therefore, the regression model (7) is adequate. Correlation coefficient $R^2 = 0,9954$.

For real values of the factors, the regression equation for the response function V_{TP1} has the form:

$$V_{TP1} = 718,8 - 3,07\omega + 14,5A - 0,0349\rho + 0,0157\omega A - 3,44 \cdot 10^{-4} \omega^2 - 3,11A^2 - 9,9 \cdot 10^{-8} \rho^2 \quad (8)$$

For the response function of a vibratory mill Q_1 with a central location of the vibration exciter, the regression equation according to the conducted multivariate experiment for coded values has the form:

$$Q_1 = 1,02 + 0,313x_1 + 0,142x_2 + 0,466x_3 + 0,0653x_1x_2 + 0,191x_1x_3 + 0,0868x_2x_3 - 0,151x_1^2 - 0,155x_2^2 - 0,0132x_3^2 \quad (9)$$

Wherein $S_{\text{aidm}}^2 = 3,77 \cdot 10^{-4}$; $S_{\text{ao}}^2 = 5,8 \cdot 10^{-4}$; $F = 1,537 < [F] = 2,881$, so the regression model (9) is adequate. Correlation coefficient $R^2 = 0,9995$. All coefficients of the regression equation (9) turned out to be significant.

For real values of the factors, the regression equation for the response function Q_1 has the form:

$$Q_1 = 134,15 - 0,358\omega + 1,99A - 0,024\rho + 1,84 \cdot 10^{-3} \omega A + 2,61 \cdot 10^{-6} \omega \rho - 1,18 \cdot 10^{-4} A\rho - 4,28 \cdot 10^{-5} \omega^2 - 0,438A^2 - 8,69 \cdot 10^{-9} \rho^2 \quad (10)$$

For the transport velocity response function V_{TP1} when the vibration exciter is placed under the grinding chambers, the regression equation according to the conducted multivariate experiment for the coded values has the form:

$$V_{TP2} = 3,5 + 1,36x_1 + 0,71x_2 - 0,498x_3 + 0,162x_1x_2 - 0,064x_1x_3 - 0,0385x_2x_3 - 0,091x_1^2 - 0,122x_2^2 - 0,0903x_3^2 \quad (11)$$

After discarding minor effects of interactions, the regression equation (11) in coded values is as follows:

$$V_{TP2} = 3,5 + 1,36x_1 + 0,71x_2 - 0,498x_3 + 0,162x_1x_2 - 0,091x_1^2 - 0,122x_2^2 - 0,0903x_3^2 \quad (12)$$

Wherein $S_{\text{aidm}}^2 = 0,0121$; $S_{\text{ao}}^2 = 0,0333$; $F = 2,766 < [F] = 2,770$, so the regression model (12) is adequate. Correlation coefficient $R^2 = 0,9995$.

For real values of the factors, the regression equation for the response function V_{TP2} has the form:

$$V_{TP2} = 158,4 - 0,911\omega + 2,57A + 0,0107\rho + 4,57 \cdot 10^{-3} \omega A - 2,57 \cdot 10^{-5} \omega^2 - 0,344A^2 - 5,93 \cdot 10^{-8} \rho^2 \quad (13)$$

For the response function of the vibratory mill Q_2 when the vibration exciter is placed under the grinding chambers, the regression equation according to the conducted multivariate experiment for the coded values has the form:

$$Q_1 = 0,415 + 0,155x_1 + 0,0734x_2 + 0,118x_3 + 0,0164x_1x_2 + 0,0636x_1x_3 + 0,0271x_2x_3 - 0,0113x_1^2 - 0,0196x_2^2 - 0,0436x_3^2 \quad (14)$$

Wherein $S_{\text{aidm}}^2 = 2,68 \cdot 10^{-4}$; $S_{\text{ao}}^2 = 5,42 \cdot 10^{-4}$; $F = 2,025 < [F] = 2,881$, therefore, the regression model (3.11) is adequate. Correlation coefficient $R^2 = 0,9995$.

All coefficients of the regression equation (14) also turned out to be significant.

For real values of the factors, the regression equation for the response function Q_2 has the form:

$$Q_2 = 37,59 - 0,0917\omega + 0,344A - 7,39 \cdot 10^{-3}\rho + 4,63 \cdot 10^{-3}\omega A + 8,67 \cdot 10^{-7}\omega\rho + 3,7 \cdot 10^{-5}A\rho - 3,19 \cdot 10^{-6}\omega^2 - 0,0553A^2 - 2,87 \cdot 10^{-8} \cdot \rho^2 \quad (15)$$

3.3 Parametric optimization of vibration mill performance

The obtained regression equations (10), (15) allow to perform parametric optimization of the productivity Q_1 , Q_2 of the vibrating mill with its maximum values.

Experiments have shown that the dependences of the values of strength Q_1 and Q_2 depend on the following parameters: vibration frequency ω , vibration amplitude A , bulk density ρ and are quadratic, and there are effects of factor interactions.

With the help of the MathCAD application package, the values of the performance values Q_2 and Q_1 were optimized by maximizing them. The result is the following optimal values of the parameters of the frequency and amplitude of vibration for different bulk density materials, which are given in Table 1 and Table 2 when placing the vibrator in the center between and under the grinding chambers, respectively.

Table 1

Optimal values of vibration parameters when placing the vibrator in the center of the oscillating masses

Bulk material	ρ , kg/m ³	ω_{opt} , 1/s	A_{opt} , mm	h , mm	V_{TP1} , mm/s	Q_{1max} , kg/s
Cherry stones $\varnothing=8,2$ mm	550	150,7	1,988	423,8	7,790	0,197
Polystyrene granules $\varnothing=3,5$ mm	610	154,8	2,001	423,0	7,923	0,222
Pea $\varnothing=6,5$ mm	800	181,5	2,041	418,5	8,329	0,302
Ceramic balls $\varnothing=6,3$ mm	1440	189,9	2,174	384,5	9,516	0,598
Steel bullets $\varnothing=6,3$ mm	4695	202,1	2,854	241,5	11,194	2,731

To compare the two arrangements of the vibrator with the central location and the lower location on the criterion of productivity, a graph of

the maximum productivity on the density of bulk material with a band of errors at confidence confidence $g=0.9$ (Figure 5).

Table 2

Optimal values of vibration parameters when placing the vibrator under the grinding chambers

Bulk material	ρ , kg/m ³	ω_{opt} , 1/s	A_{opt} , mm	h, mm	V_{TP1} , mm/s	Q_{1max} , kg/s
Cherry stones $\varnothing=8,2$ mm	550	217,7	2,048	432,8	4,434	0,100
Polystyrene granules $\varnothing=3,5$ mm	610	218,6	2,050	429,9	4,446	0,114
Pea $\varnothing=6,5$ mm	800	221,2	2,058	420,5	4,480	0,156
Ceramic balls $\varnothing=6,3$ mm	1440	230,1	2,083	386,6	4,563	0,285
Steel bullets $\varnothing=6,3$ mm	4695	275,2	2,210	165,0	4,195	0,666

As a result of the analysis of the graph shown in Figure 5 shows that the central location of the vibrator (in the center of the vibrational masses) is 2-3 times more efficient than in the case of its location below, under the grinding chambers.

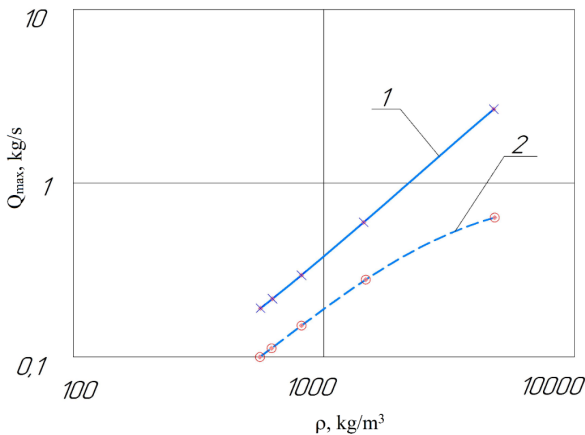

Figure 5. Dependence of maximum productivity Q_{max} on the density of bulk material ρ for different schemes of vibrating excitation: 1 – with a central location; 2 – with the lower location

When the vibrator is located under the grinding chambers, ie not in the center of the oscillating masses, the trajectories of the points of the body are generally ellipses (in particular – straight or arcs). The center of gravity of the system oscillates in a circular trajectory with radius $r = \frac{m\varepsilon}{M}$ where ε – is the static moment of unbalance of the vibrator, M – is the mass of the system, while the system itself oscillates around the oscillation center, located from the center of gravity at a distance $S = \frac{J}{Mh} = \frac{\rho^2}{h}$ where $J = Mp^2$ the moment of inertia relative to the axis O_1Z , perpendicular to the plane of the drawing ρ – is the corresponding radius of inertia, h – is the distance O_1D . This can be explained by the fact that when the vibrator is located in the center of mass of the oscillating system, it makes plane-parallel oscillations along a circular trajectory, ie at any point of the oscillating body trajectory of its movement is the same and have the shape of a circle. The point K oscillates rectilinearly along the line DO_1K with amplitude $r = \frac{m\varepsilon}{M}$ [13].

Such complex oscillations of the working body of the vibrating mill, and with it the transition chute 10, determine the complexity of the movement of loading from one grinding chamber to another and, as a consequence, the movement of loading along grinding chambers. The diagram of the plane field of oscillations presented in Figure 6 it shows.

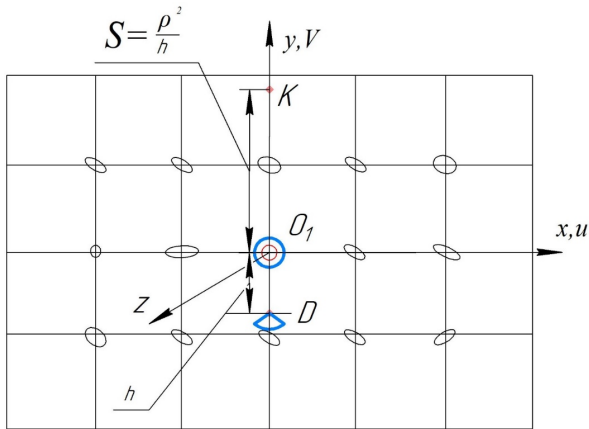

Figure 6. Diagram of a plane field of oscillations

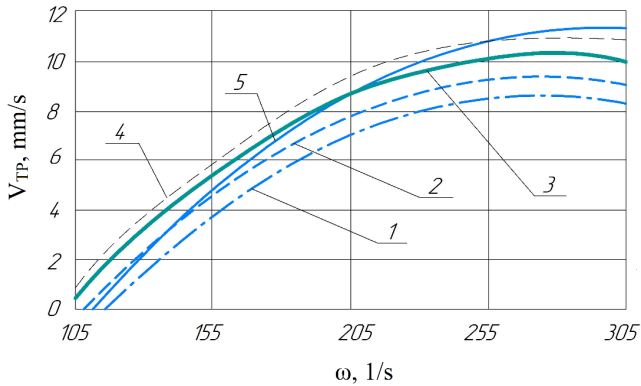

Figure 7. Graph of the dependence of the transport velocity V_{TP} on the frequency ω at the optimal value of the amplitude A for different bulk materials: 1 – cherry stones; 2 – polystyrene granules; 3 – peas; 4 – ceramic balls, 5 – steel balls

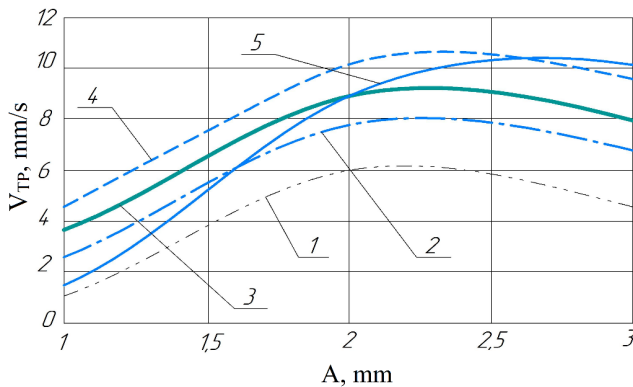

Figure 8. Graph of the dependence of the transport velocity V_{TP} on the amplitude A at the optimal frequency ω value for different bulk materials: 1 – cherry stones; 2 – polystyrene granules; 3 – peas; 4 – ceramic balls, 5 – steel balls

In Figure 7 shows a graph of the dependence of the transport velocity on the frequency at the optimal value of the amplitude.

In Figure 8 shows a graph of the dependence of the transport velocity on the amplitude at the optimal frequency for different bulk materials.

4. Model of adaptive vibrating mill with spatial circulation movement

Due to the complexity of dynamic processes occurring both in the process load and in its interaction with the vibrating body, in many works it was proposed [1; 13; 14; 15] to take into account the influence of the mass of filler in the form of equivalent mass attached to the container. Studies have shown that taking into account the inertial properties of the technological load can be done with a nonlinear element $a \cdot \omega^2/g$ that uniquely determines the phase angles of separation φ_B and meeting φ_3 of the material with the working body, thereby specifying the type of relay contact characteristics of the material with vibration mill housing.

It is shown that the use of feedback in oscillating mechanical systems of resonant type allows to synchronize the influence of external cyclic forcing force and the natural oscillations of the mechanical oscillating system. As a result, when the time of the reduced mass of vibrating machines changes, the frequency of the forcing cyclic force changes, thus providing a constant resonant mode of operation of the vibrating technological machine (VTM).

The authors propose a fundamentally new method of controlling the operation of adaptive vibrating technological machines that allows to optimize the process of tuning to a constant resonant mode and ensure optimal operating modes with minimal energy consumption for the vibratory drive [2; 28]. The reduction of energy consumption of the given control method is due to the fact that such control allows faster correction of non-resonant mode of operation, and as a result the machine will work less time in economically unfavorable non-resonant modes.

In addition, this method minimizes the sharp increase in the amplitude of oscillations in transients, which are usually observed when changing the load mass or changing operating modes and process parameters. When considering the operation of vibrating mill as an element in technological lines and complexes to maintain technologically determined optimal parameters, it is advisable to pay attention to stabilizing its main characteristics such as productivity and intensity of vibration destruction

(product particles are destroyed by shock load and friction forces bodies). To stabilize the productivity of vibration mills, it is advisable to use the technology developed by the authors in the work, which allows for minimal energy consumption of the vibratory drive to provide optimal from a technological point of view parameters of the vibration field.

In world practice, vibration technologies are widely used vibration machines of continuous action. The working chamber of such machines can have both circular and spiral shape. Significant velocity of mechanical and heat and mass transfer processes, a high degree of homogeneity of the product, the ability to effectively implement fine grinding and dispersion of the product at relatively low energy consumption lead to the widespread use of vibratory grinding.

Vibrating mills combine a fairly high intensity of technological action with a relatively simple design. The specific productivity of these machines is almost 5 times higher than similar parameters for centrifugal mills. As a basis, to develop a structural model of vibration mill with spatial-circulating loading movement which when changing the mass of the working body (in the process of separation and unloading of crushed material from the grinding chamber) constantly adapts to resonant mode at predetermined technologically optimal parameters (productivity) and minimum energy consumption for the vibratory drive, it is advisable to use a vibrating mill VM-400 (Figure 9) which is protected by a patent of Ukraine [1; 31].

Vibration mill consists of a grinding chamber 1 which is mounted on elastic supports 2. The working body is closed by means of reloading-chewing 6 and transitional chutes 4 grinding chambers 7, loading sleeve 8, which are filled with loading. Under the action of the vibration field, the load 5 in the left grinding chamber 4 rises along the vertical chute 1 and flows through the transport tray 2 into the right grinding chamber. The crushed material is sifted through the unloading grid 3 to the exit of the mill, and the working bodies are taken to the front of the right grinding chamber in the loading area of the crushed material.

In the front part of the right grinding chamber due to the continuous transition through the chute 1 and the transport tray 2 an increased load level is formed, crushed material also enters here, and in the rear part, due to the transition of the loading part to the left grinding chamber – reduced level. In the left grinding chamber due to the selection of the load in the front part

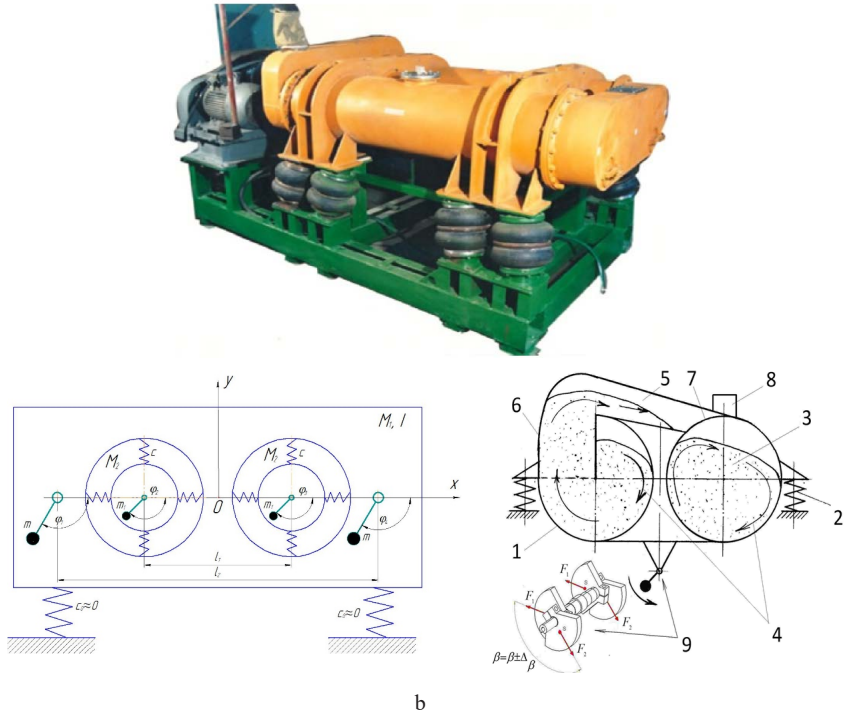

Figure 9. Vibrating mill MV-400:
a) general view of industrial model; b) kinematic scheme

of its reduced level is formed, and in the rear, due to the influx of load from the right grinding chamber – increased. Thus in the interconnected grinding chambers the spatial-circulating movement of loading on the closed helical trajectory is formed.

Remotely controlled unbalanced vibratory drive 9 mounted on the grinding chamber 1 and is a source of cyclic forcing force is driven by an electric motor 13. The electric motor 13 is connected to the frequency synthesis unit of the perturbing cyclic forcing force 19, and this unit is connected to the comparator 16 and input phase shift detector 15. The second input of the phase shift detector 15 is connected to the vibration sensor 14 located on the grinding chamber 1. The vibration sensor is also connected to the optimal parameter

synthesis unit 17 and the comparator 18. The optimal parameter synthesis unit 17 is connected with two comparators 18 and 16. The comparator 18 is connected to the unit of synthesis of the amplitude of the perturbing force 20 which in turn is connected to the unit of influence on the eccentricity of the imbalances of the controlled unbalanced vibrating drive 9.

In Figure 10 shows the proposed model of adaptive vibration mill with spatial-circulating loading motion.

The principle of operation of the proposed adaptive vibratory mill is as follows. As a result of the operation of the controlled unbalanced vibration exciter 9, the grinding chamber 1 of the adaptive vibration mill performs elliptical oscillations, as a result of which, in accordance with the emerging effect of vibration transportation of the granular medium. The movement of this medium occurs in a closed cycle (position 4 in figure 10).

The number of cyclic passes of a certain arbitrary continuous (integral) element of the bulk medium and elements formed during its grinding is determined by the size of the unloading lattice 11, ie as soon as the size of the crushed elements becomes smaller than the holes of the unloading lattice through the sleeve 12 in the form of finished products. The weight of the finished product leaving the adaptive vibration mill $\Delta M_v = f(t)$ through the sleeve 12 is a complex variable over time, which takes into account many factors due to which the destruction of products in a closed operating cycle of adaptive vibration mill.

The destruction of an integral non-uniform volume of material, especially natural minerals, will depend on the structure of the substances of which it consists and their percentage, and different parts of a heterogeneous volume of material are characterized by an unequal content of such substances, both in percentage and structural terms. Therefore, the time spent on the destruction of various components of premixes will be different and it is quite difficult to predict the behavior of the function over time. As a result of constant removal of finished products from the adaptive vibration mill through the sleeve 12 leads to a constant change in time of the natural resonant frequency of the adaptive vibration mill.

To replenish the mass of bulk material in the grinding chamber 1 of the adaptive vibrating mill and perform its direct technological purpose through the loading sleeve 8, a time-constant loading of the material is crushed $\Delta M_z = f(t)$, which occurs in the adaptive vibrating mill.

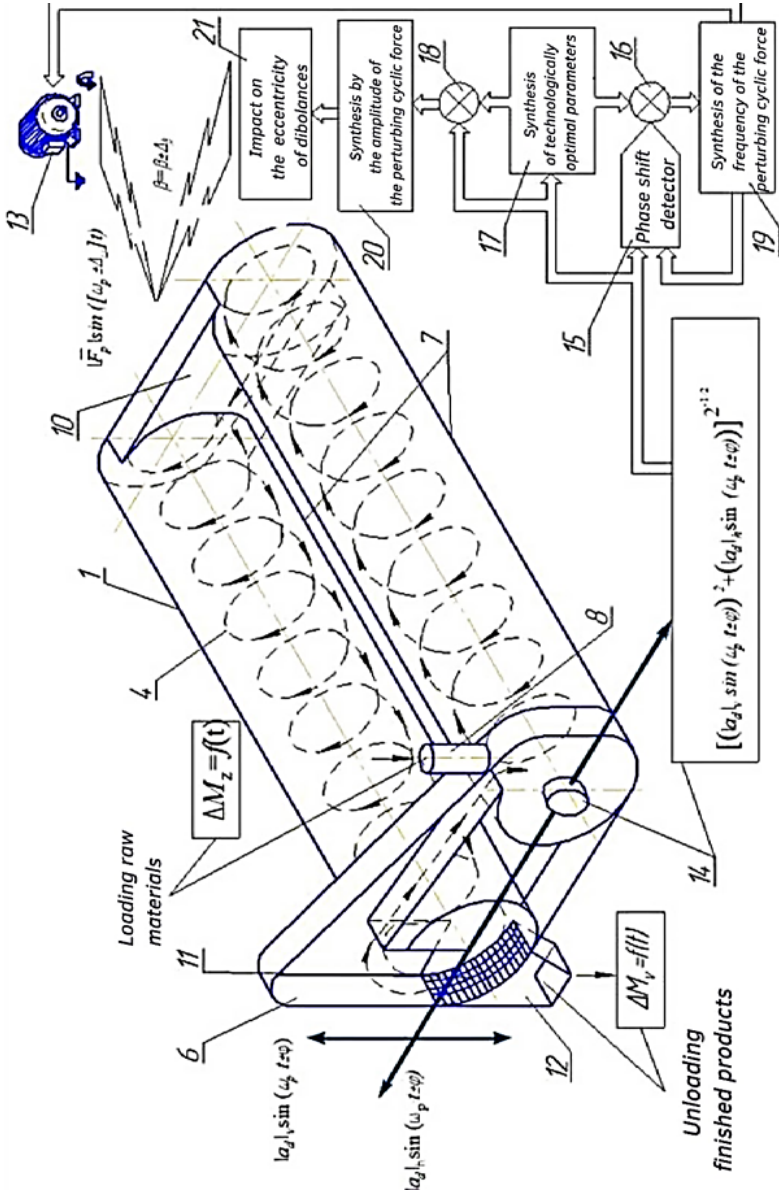

Figure 10. Model of adaptive vibration mill with spatial-circulating loading movement

The function $\Delta M_z = f(t)$ is also the $\Delta M_v = f(t)$ cause of instability and change in time of the natural resonant frequency of the adaptive vibration mill, ie it is a disturbing factor if the adaptive vibration mill is considered as an object of control. As a result of the operation of the controlled unbalanced vibrating exciter 9 and the elliptical movements of the grinding chamber 1 there is a constant unloading through 12 finished and loading through 8 not yet crushed products.

In order to reduce energy consumption for unbalanced vibratory drive and increase the productivity of the vibration mill on the grinding chamber 1 vibration sensor 14 is placed. The information from this vibration sensor 14 contains information about the actual instantaneous value of the horizontal $|a_d|_h \cdot \sin(\omega_p t \pm \varphi)$ and the actual instantaneous value of the vertical $|a_d|_v \cdot \sin(\omega_p t \pm \varphi)$ component of the forced oscillations of the grinding chamber 1 of the adaptive vibration mill. This information from the sensor 14 is fed to one of the inputs of the phase shift detector 15 and the input of the unit 17 synthesis of technologically optimal parameters of the vibration field of the grinding chamber 1 adaptive vibration mill and the input of the comparator 18. The second input of the phase shift detector 15 receives information from block 19 of the perturbing cyclic forcing force of the unbalanced vibrating $|F_p| \cdot \sin((\omega_p \pm \Delta_\omega) \cdot t)$ drive about the frequency of the cyclic forcing force with which the electric motor 13 drives the unbalanced vibrating drive 9 and the grinding chamber accordingly.

Given the fact that in the resonance zone of the vibrating machine there is a very sharp change in phase angle, and at resonance there is a lag of forced oscillations of the grinding chamber 1 from the cyclic forcing force of the vibrating drive 9 for a quarter period ($\varepsilon = \pi/2$) and the forcing force of the vibratory drive 9 and calculating it in real time by its value can be clearly and unambiguously determined in which direction from the resonant mode and how far the oscillating system of adaptive vibration mill due to changes in mass ($\Delta M_z + \Delta M_v$) of the grinding chamber 1. That is, phase shift detector 15 generates a function of the time variable relative to the resonance point ($\varepsilon = \pi/2$) of the vibration mill $\varepsilon(t) = [\pi/2] \pm \Delta(t)$, where $\Delta(t) = \varepsilon_1(t) - \varepsilon_2(t)$, where $\Delta\varepsilon_1(t)$ and $\Delta\varepsilon_2(t)$ oscillating system, where is the angle between the natural oscillations of the grinding chamber 1 and the cyclic forcing force of the vibrating drive 9 in t_1 and t_2 time and respectively.

This information $\varepsilon(t)$ in the process of adaptive vibration mill is continuously transmitted to the comparator 16 where it is compared with the information coming from the unit 17 for the synthesis of technologically optimal parameters of the vibration field of the adaptive vibration mill. Technologically optimal from the point of view of energy saving is the mode of operation of the vibration mill at which $\varepsilon = \pi/2$ (resonant mode of operation $\omega_p = \omega_0$ where ω_0 – the natural resonant frequency of the vibrating machine). Therefore, in the comparator 16 there is a constant in time comparison $\varepsilon(t) = \pi/2$ and, accordingly, the difference $(\pi/2) - \varepsilon(t)$ in the block 19 of the synthesis of the frequency of the perturbing cyclic forcing force is formed by the change in the frequency of the perturbing cyclic forcing force by the value $\pm\Delta_\omega$.

The magnitude of the correction $\pm\Delta_\omega$ for the frequency of the perturbing cyclic forcing force $|F_p| \cdot \sin((\omega_p \pm \Delta_\omega) \cdot t)$ is always aimed at ensuring constant equality over time $\varepsilon_1(t) - \varepsilon_2(t) = \pi/2$. As a result of constant correction of the frequency of the perturbing cyclic forcing force ($\omega_p \pm \Delta_\omega$), a constant resonant mode of vibration mill operation is provided by adapting the forcing cyclic force frequency to the time variable (due to the change of grinding chamber mass $\Delta M_z + \Delta M_v$, 1). This principle of controlling the operation ω_0 of the vibration mill and this design of the vibration mill, provide minimal energy consumption for the vibratory drive due to the constant resonant mode of operation.

In order to ensure the stability over time of the optimal predetermined technological parameters of the vibration field of the adaptive vibration mill with minimal energy costs for the vibratory drive, the second control circuit (stabilization) is used. When the natural resonant frequency $\omega_0 \pm \Delta_\omega$ of the adaptive vibration mill changes, the energy parameters of the vibration field also change, which in turn leads to a change in the intensity of vibration processing (destruction).

During the operation of the adaptive vibration mill and during constant in the time of its adjustment to the resonant mode by use operation unit 17, synthesis of technologically optimal parameters of the vibration field of the adaptive vibration mill was monitors use the sensor 14 (two parameters of the grinding chamber 1 are determine). These parameters are ω_d and a_d the actual (currently) frequency and amplitude oscillations of the grinding chamber 1 of the adaptive vibration mill.

If the criterion for estimating the vibration field of the adaptive vibration mill is taken as the specific work $A_p = \omega_d^2 \times a_d^2$ of the forcing force of the unbalanced vibrating drive 9, the unit 17 will calculate $\omega_0 \pm \Delta_\omega$ the required amplitude of oscillations at a given time frequency so that the product does not change over time $\omega_d^2 \times a_d^2$. That is, at the output of block 17, we constantly obtain the value of the required level of amplitude of oscillations of the grinding chamber 1 at a given (actual) frequency of its oscillations.

Given the fact that the oscillations of the adaptive vibration mill are forced, the frequency of oscillations ω_p of the unbalanced vibrating drive 9 is identical in value with the actual oscillation frequency ω_d of the grinding chamber 1, and the fact that the first control circuit constantly adapts the frequency unbalanced vibrating drive 9 to the frequency of natural resonant vibrations ω_0 of the vibrating mill then $\omega_p = \omega_d \rightarrow \omega_0$. Based on this, the calculation of the required amplitude of oscillations at a given resonant frequency will be carried out from the following relationship: $a_n = [\omega_z^2 \times a_z^2] / \omega_0^2$, where ω_z^2 and a_z^2 optimal parameters of the vibration field of the adaptive vibration mill are set from a technological point of view.

In the comparator 18 the required value of the amplitude of oscillations a_n of the grinding chamber 1 is compared with the actual value of the amplitude of oscillations a_d of the grinding chamber 1 and based on the comparison in the unit 20 synthesis of the amplitude of or the center of the rotational forces arising from their rotation relative to the axis of the unbalance shaft will be the same modulus and will be determined by the expression $|\vec{F}_1| = |\vec{F}_2| = m \cdot e \cdot \omega_p$ where m and e the mass and eccentricity of the unbalance of the vibrating drive 9.

The total cyclic forcing force of the unbalanced vibrating drive 9:

$$\vec{F}_p = |\vec{F}_1| + |\vec{F}_2|. \quad (16)$$

or

$$F_p = 2 \cdot \sqrt{F_1^2 + F_2^2 + 2 \cdot F_1 \cdot F_2 \cdot \cos(\beta \pm \Delta_\beta)} \cdot \sin((\omega_p \pm \Delta_\omega) \cdot t). \quad (17)$$

Thus, on the basis of the unit 21 changes the angle between the imbalances of the vibratory drive in order to obtain the desired value of the amplitude of oscillations of the grinding chamber 1 to stabilize in time the specific work of the vibrating field of the grinding chamber 1, ie ensuring the equality of this ratio: $\omega_0^2 \times a_n^2 = \omega_z^2 \times a_z^2 = const$.

In the process of operation of the proposed adaptive vibration mill with spatial-circulating motion of the bulk medium loading, two control (adjustment) circuits work independently. The contour of adjustment to the resonant mode of operation, the composition of which can be conditionally included in the following positions 1, 14, 15, 16, 17, 19, 13, 9. The contour of adjustment to the technologically optimal parameters of the vibration field of the grinding chamber the following positions 1, 14, 17, 18, 20, 21, 9 can be credited in successive order. resonant frequency of adaptive vibration mill.

In the expression (17), which describing the cyclic forcing force of the unbalanced vibrating actuator 9 of the adaptive vibration mill, the first control circuit changes the frequency of the cyclic forcing force of the vibrating actuator 9 ($\omega_p \pm \Delta_\omega$) and the second control circuit changes the amplitude of the cyclic forcing force of the vibrating actuator 9 ($\beta \pm \Delta_\beta$).

5. Conclusions

1. The results of experiments proved that the most promising are vibrating mills with a closed shape of grinding chambers. The highest lifting height was observed when installing a gutter near the outer side wall of one of the grinding chambers in the area of impact of the load. Position of the lower end of the gutter, located from the bottom of the grinding chamber at a distance of the radius of its curvature, is optimal. The greatest height of lifting of loading in a trench was provided at its length $\ell = r$.

2. Regression equations were obtained by the method of multivariate experiment planning, which allow to adequately describe the dependences of the values of vibration mill productivity q_1 and q_2 on the main influence parameters: vibration frequency ω , vibration amplitude a , bulk density ρ .

3. Parametric optimization of vibration mill productivity values at the central location of the vibration exciter q_1 was carried out, which allowed to obtain optimal values of vibration parameters: $\omega = 150 \dots 200$ 1/s, $a = 1.9 \dots 2.8$ mm for materials with bulk density $\rho = 600 \dots 4700$ kg/m³, and the maximum values of the optimization criterion: $q_1 = 0.2 \dots 2.7$ kg/s. Parametric optimization of the values of vibration mill productivity values when placing the vibrator under the grinding chambers q_2 , which allowed to obtain optimal values of vibration parameters: $\omega = 210 \dots 270$ 1/s,

and = 2.0... 2.2 mm for materials with bulk density $\rho = 600 \dots 4700 \text{ kg/m}^3$, and the maximum values of the optimization criterion: $q_2 = 0.1 \dots 0.67 \text{ kg/s}$.

4. Dependence of the transport velocity on the frequency at the optimal value of the amplitude and of the transport velocity on the amplitude at the optimal frequency for different bulk materials are identified. Also, as a result of comparison of two schemes of vibrating exciter placement in the center of vibrating masses (with central location) and with vibrating exciter placement under grinding chambers according to the performance criterion it is established that the scheme with central vibrating exciter placement (in the center of oscillating masses) is 2-4 times more productive.

5. The proposed structure and two-circuit principle of control of adaptive vibration mill with spatial-circulating loading movement, provide minimal energy consumption for the vibratory drive due to constant resonant mode of operation at predetermined technologically optimal parameters of the vibration field of the vibration mill grinding chamber.

In the process of operation of the proposed adaptive vibration mill with spatial-circulating motion of bulk medium loading, two control circuits (adjustment) work independently: the first control circuit is the main and has the highest priority for correction of resonant mode of vibration mill operation, forcing force already at the resonant frequency of the adaptive vibration mill.

References:

1. Bernik P.S., Denisov P.D., Solona O.V. Vibrating mill. *Patent UA*, 43792.
2. Borysiuk D., Spirin A., Kupchuk I., Tverdokhlib I., Zelinskyi V., Smyrnov Ye., Ognevyy V. (2021) The methodology of determining the place of installation of accelerometers during vibrodiagnostic of controlled axes of wheeled tractors. *Przegląd Elektrotechniczny*, vol. 97, no. 10, pp. 44–48. DOI: <https://doi.org/10.15199/48.2021.10.09>
3. Gunko I., Hraniak V., Yaropud V., Kupchuk I., Rutkevych V. (2021) Optical sensor of harmful air impurity concentration. *Przegląd Elektrotechniczny*, vol. 97, no. 7, pp. 76–79. DOI: <https://doi.org/10.15199/48.2021.07.15>
4. Honcharuk I., Kupchuk I., Solona O., Tokarchuk O., Telekalo N. (2021) Experimental research of oscillation parameters of vibrating-rotor crusher. *Przegląd Elektrotechniczny*, vol. 97, no. 3, pp. 97–100. DOI: <https://doi.org/10.15199/48.2021.03.19>
5. Hrushetskyi S., Yaropud V., Kupchuk I., Semenyshena R. (2021) The heap parts movement on the shareboard surface of the potato harvesting machine. *Bulletin of the Transilvania University of Braşov. Series II: Forestry, Wood Industry*,

Agricultural Food Engineering, vol. 14(63), no. 1, pp. 127–140. DOI: <https://doi.org/10.31926/but.fwiafe.2021.14.63.1.12>

6. Hvozdiev O. V., Shpyhanovych T. O., Yalpachyk O. V. (2011) Improvement of grain grinding process. *Collection of scientific works of Vinnytsia National Agrarian University. Series: Technical Sciences*, no. 11, pp. 143–150.

7. Kaletnik G. M., Yanovych V. P. (2017) Substantiation of operating and design parameters of a gyration mill for the production of highly active premixes. *Vibrations in engineering and technology*, no. 1, 84, pp. 15–21.

8. Komakha V., Burlaka S., Kupchuk I., Yatskovska R. (2018) Analysis of technologies of sowing and sowing. *Silске hospodarstvo ta lisnytstvo*, no. 11, pp. 123–131.

9. Kovbasa V., Solona O., Deikun V., Kupchuk I. (2021) Functions derivation of stresses in the soil and resistance forces to the motion of a plough share for cavity creation. *UPB Scientific Bulletin, Series D: Mechanical Engineering*, 83(3), pp. 305–318.

10. Kudinov Ye. S., Boiko I. H. (2010) Analysis of methods for grinding grain feed in accordance with their energy intensity. *Bulletin of the Kharkiv National Technical University of Agriculture named after Peter Vasylenko. Series: Technical Sciences*, no. 3, 95, pp. 5–12.

11. Kupchuk I. M., Solona O. V., Derevenko I. A., Tverdokhlib I. V. (2018) Verification of the mathematical model of the energy consumption drive for vibrating disc crusher. *INMATEH – Agricultural Engineering*, vol. 55, no. 2, pp. 113–120.

12. Kupchuk I., Kolisnyk M., Shtuts A., Paladii M. (2021) Development of the technological process of forming rings from sheet samples by stamping rollers and rotary hood. *Bulletin of the Transilvania University of Braşov. Series I: Engineering Sciences*, vol. 14(63), no. 2, pp. 1–13. DOI: <https://doi.org/10.31926/but.ens.2021.14.63.2.1>

13. Kupchuk I., Kolisnyk M., Shtuts A., Paladii M., Didyk A. (2021) Experimental evaluation stress-strain state for billets during rolling stamping by rollers. *Colloquium-journal*, no. 16 (103), część 1, pp. 40–48.

14. Kupchuk I., Poberezhets Yu., Kravets R. (2021) Research of the rheological parameters of feed grain in the process of the combined impact-cutting grinding. *Tekhnika, enerhetyka, transport APK*, no. 3(114), pp. 49–58.

15. Kupchuk I., Telekalo N. (2021) Substantiation of the constructive and mode parameters of vibratory disc crusher for the farm animals compound feeds production. Development of scientific, technological and innovation space in Ukraine and EU countries. Collective monograph. Riga, Latvia: “Baltija Publishing”, pp. 166–194.

16. Kupchuk I., Yaropud V., Hraniak V., Poberezhets Ju., Tokarchuk O., Hontar V., Didyk A. (2021) Multicriteria compromise optimization of feed grain grinding process. *Przegląd Elektrotechniczny*, vol. 97, no. 11, pp. 179–183. DOI: <https://doi.org/10.15199/48.2021.11.33>

17. Kuznietsova I., Bandura V., Paziuk V., Tokarchuk O., Kupchuk I. (2020) Application of the differential scanning calorimetry method in the study of the tomato fruits drying process. *Agraarteadus*, vol. 31, no. 2, pp. 173–180. DOI: <https://doi.org/10.15159/jas.20.14>

18. Matvijchuk V., Shtuts A., Kolisnyk M., Kupchuk I., Derevenko I. (2022) Investigation of the tubular and cylindrical billets stamping by rolling process with the use of computer simulation. *Periodica Polytechnica Mechanical Engineering*, vol. 66, no. 1, pp. 51–58. DOI: <https://doi.org/10.3311/PPme.18659>
19. Mazur V., Tkachuk O., Pantsyryeva H., Kupchuk I., Mordvaniuk M., Chynchyk O. (2021) Ecological suitability peas (*Pisum Sativum*) varieties to climate change in Ukraine. *Agraarteadus*, vol. 32, no. 2, pp. 276–283. DOI: <https://doi.org/10.15159/jas.21.26>
20. Palamarchuk V., Honcharuk I., Telekalo N., Krychkovskyi V., Kupchuk I., Mordvaniuk M. (2021) Modeling of hybrid cultivation technology corn to ensure energy efficiency for sustainable rural development. *Ukrainian Journal of Ecology*, no. 11(7), pp. 204–211. DOI: https://doi.org/10.15421/2021_260
21. Paziuk V., Vyshnevskiy V., Tokarchuk O., Kupchuk I. (2021) Substantiation of the energy efficient schedules of drying grain seeds. *Bulletin of the Transilvania University of Braşov. Series II: Forestry, Wood Industry, Agricultural Food Engineering*, vol. 14(63), no. 2, pp. 137–146. DOI: <https://doi.org/10.31926/but.fwiafe.2021.14.63.2.13>
22. Poberezhets J., Kupchuk I. (2021) Effectiveness of the use of probiotics in the diet of broiler chickens. *Roczniki Naukowe Polskiego Towarzystwa Zootechnicznego*, vol. 17(4), pp. 9–16.
23. Poberezhets J., Kupchuk I., Yaropud V., Burlaka S. (2021) Digestibility of nutrients and broiler chicken productivity under the action of probiotic enteroactive. *Visnyk Khmelnytskoho natsionalnoho universytetu. Seria: Tekhnichni nauky*, no. 4 (299), pp. 182–186.
24. Poberezhets Ju., Chudak R., Kupchuk, I., Yaropud V., Rutkevych V. (2021) Effect of probiotic supplement on nutrient digestibility and production traits on broiler chicken. *Agraarteadus*, vol. 32, no. 2, pp. 296–302. DOI: <https://doi.org/10.15159/jas.21.28>
25. Rutkevych V., Kupchuk I., Yaropud V., Hraniak V., Burlaka S. (2022) Numerical simulation of the liquid distribution problem by an adaptive flow distributor. *Przegląd Elektrotechniczny*, vol. 98, no. 2, pp. 64–69. DOI: <https://doi.org/10.15199/48.2022.02.13>
26. Solona O., Derevenko I., Kupchuk I. (2019) Determination of plasticity for pre-deformed billet. *Solid State Phenomena*, vol. 291, pp. 110–120. DOI: <https://doi.org/10.4028/www.scientific.net/ssp.291.110>
27. Solona O., Kovbasa V., Kupchuk I. (2020) Analytical study of soil strain rate with a ploughshare for uncovering slit. *Agraarteadus*, vol. 31, no. 2, pp. 212–218. DOI: <https://doi.org/10.15159/jas.20.22>
28. Solona O., Kupchuk I. (2020) Dynamic synchronization of vibration excitors of the three-mass vibration mill *Przegląd Elektrotechniczny*, vol. 96, no. 3, pp. 161–165. DOI: <https://doi.org/10.15199/48.2020.03.35>
29. Solona O. V. (2008) Vibration mills with space-circulation loading for fine grinding of bulk materials. *Vinnitsia State Agrarian University*, p. 133.
30. Solona O. V., Kovbasa V. P., Kupchuk I. M. (2020) The contact interaction dynamics of the working tool of the mole plowshare with the soil during forming

prosess a channel for an anti-filtration screen. *Vibratsii v tekhnitsi ta tekhnolohiiakh*, no. 2(97), pp. 81–89.

31. Solona O. V., Yanovych V. P., Melnyk O. S. Vibrating mill. *Patent UA*, 109539.

32. Yanovich V. P., Kupchuk I. M. (2017) Determination of rational operating parameters for a vibrating dysk-type grinder used in ethanol industry. *INMATEH – Agricultural Engineering*, vol. 52, no. 2, pp. 143–148.

33. Yanovich V. P., Tsurkan O. V. (2017) Analysis of the mathematical model of vibrating milling of angular oscillations. *Motrol. Commission of Motorization and Energetics in Agriculture*, no. 2, 19, pp. 139–144.

34. Yanovych V., Kupchuk I., Kovalchuk O. (2016) The teoretical studies of energy parameters of vibration-disk crusher starch containing substance. *SWorld journal: Technical sciences*, issue 11, pp. 17–24.

35. Yanovych V., Kupchuk I. (2017) Development of movement mathematical model for executive bodies of gyroscope-type mill. *SWorld journal: Technical sciences*, issue 13, pp. 174–184.

36. Yaropud V., Hunko I., Aliiev E., Kupchuk I. (2021) Justification of the mechatronic system for pigsty microclimate maintenance. *Agraarteadus*, vol. 32, no. 2, pp. 212–218. DOI: <https://doi.org/10.15159/jas.21.21>